

COPYRIGHT © Hangzhou EZVIZ Software Co., Ltd. ALL RIGHTS RESERVED.

Any and all information, including, among others, wordings, pictures, graphs are the properties of Hangzhou EZVIZ Software Co., Ltd. (hereinafter referred to as "EZVIZ"). This user manual (hereinafter referred to as "the Manual") cannot be reproduced, changed, translated, or distributed, partially or wholly, by any means, without the prior written permission of EZVIZ. Unless otherwise stipulated, EZVIZ does not make any warranties, guarantees or representations, express or implied, regarding to the Manual.

About this Manual

The Manual includes instructions for using and managing the product. Pictures, charts, images and all other information hereinafter are for description and explanation only. The information contained in the Manual is subject to change, without notice, due to firmware updates or other reasons. Please find the latest version in the EZVIZ™ website (<http://www.ezviz.com>).

Revision Record

New release - April, 2026

Trademarks Acknowledgement

EZVIZ™, ™, and other EZVIZ's trademarks and logos are the properties of EZVIZ in various jurisdictions. Other trademarks and logos mentioned below are the properties of their respective owners.

Legal Disclaimer

TO THE MAXIMUM EXTENT PERMITTED BY APPLICABLE LAW, THE PRODUCT DESCRIBED, WITH ITS HARDWARE, SOFTWARE AND FIRMWARE, IS PROVIDED "AS IS", WITH ALL FAULTS AND ERRORS, AND EZVIZ MAKES NO WARRANTIES, EXPRESS OR IMPLIED, INCLUDING WITHOUT LIMITATION, MERCHANTABILITY, SATISFACTORY QUALITY, FITNESS FOR A PARTICULAR PURPOSE, AND NON-INFRINGEMENT OF THIRD PARTY. IN NO EVENT WILL EZVIZ, ITS DIRECTORS, OFFICERS, EMPLOYEES, OR AGENTS BE LIABLE TO YOU FOR ANY SPECIAL, CONSEQUENTIAL, INCIDENTAL, OR INDIRECT DAMAGES, INCLUDING, AMONG OTHERS, DAMAGES FOR LOSS OF BUSINESS PROFITS, BUSINESS INTERRUPTION, OR LOSS OF DATA OR DOCUMENTATION, IN CONNECTION WITH THE USE OF THIS PRODUCT, EVEN IF EZVIZ HAS BEEN ADVISED OF THE POSSIBILITY OF SUCH DAMAGES.

TO THE MAXIMUM EXTENT PERMITTED BY APPLICABLE LAW, IN NO EVENT SHALL EZVIZ'S TOTAL LIABILITY FOR ALL DAMAGES EXCEED THE ORIGINAL PURCHASE PRICE OF THE PRODUCT.

EZVIZ DOES NOT UNDERTAKE ANY LIABILITY FOR PERSONAL INJURY OR PROPERTY DAMAGE AS THE RESULT OF PRODUCT INTERRUPTION OR SERVICE TERMINATION CAUSED BY: A) IMPROPER INSTALLATION OR USAGE OTHER THAN AS REQUESTED; B) THE PROTECTION OF NATIONAL OR PUBLIC INTERESTS; C) FORCE MAJEURE; D) YOURSELF OR THE THIRD PARTY, INCLUDING WITHOUT LIMITATION, USING ANY THIRD PARTY'S PRODUCTS, SOFTWARE, APPLICATIONS, AND AMONG OTHERS.

REGARDING TO THE PRODUCT WITH INTERNET ACCESS, THE USE OF PRODUCT SHALL BE WHOLLY AT YOUR OWN RISKS. EZVIZ SHALL NOT TAKE ANY RESPONSIBILITIES FOR ABNORMAL OPERATION, PRIVACY LEAKAGE OR OTHER DAMAGES RESULTING FROM CYBER ATTACK, HACKER ATTACK, VIRUS INSPECTION, OR OTHER INTERNET SECURITY RISKS; HOWEVER, EZVIZ WILL PROVIDE TIMELY TECHNICAL SUPPORT IF REQUIRED. SURVEILLANCE LAWS AND DATA PROTECTION LAWS VARY BY JURISDICTION. PLEASE CHECK ALL RELEVANT LAWS IN YOUR JURISDICTION BEFORE USING THIS PRODUCT IN ORDER TO ENSURE THAT YOUR USE CONFORMS TO THE APPLICABLE LAW. EZVIZ SHALL NOT BE LIABLE IN THE EVENT THAT THIS PRODUCT IS USED WITH ILLEGITIMATE PURPOSES.

IN THE EVENT OF ANY CONFLICTS BETWEEN THE ABOVE AND THE APPLICABLE LAW, THE LATTER PREVAILS.

Table of Contents

Overview	1
1. Package Contents	1
2. Basics	1
Get the EZVIZ App	3
Connect to Power	3
Connect to Internet	3
Option A: Wired Setup	4
Option B: Wi-Fi Setup	4
Installation	5
1. Install a microSD™ Card (Optional)	5
2. Installation Location	5
3. Remove Mounting Bracket	5
4. Installation Procedure	6
5. Install the waterproof kit (Optional)	7
View Your Device	8
1. Live View	8
2. Intelligent Detection	9
EZVIZ Connect	10
1. Use Amazon Alexa	10
2. Use Google Assistant	11
FAQ	12
Initiatives on the Use of Video Products	13
Information For Private Households	14

Overview

1. Package Contents



Camera (×1)

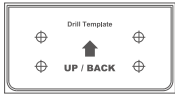

Drill Template (×1)



Waterproof Kit (×1)

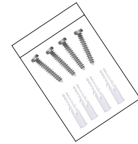

Screw Kit (×1)



Power Adapter (×1)



Regulatory Information (×2)







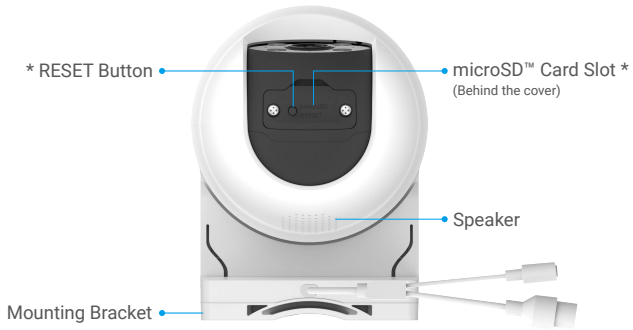

Quick Start Guide (×1)

i The power adapter's appearance is subject to the one you have bought.

2. Basics





Name	Description
Red/Blue Lights	<ul style="list-style-type: none"> • Alarm After adding the camera to EZVIZ app, you can enable alarm on the camera's live view page. The red/blue lights flash in red and blue alternately. • Intelligent Detection After adding the camera to EZVIZ app, you can enable the intelligent detection (for details, refer to the "Intelligent Detection"). When detection is triggered, the camera will display visual alerts based on the parameters set in the "Light Settings". <p>i To ensure that intelligent detection functions properly, enable the corresponding lights in EZVIZ app under Settings > Light Settings.</p>
LED Indicator	<ul style="list-style-type: none">  Solid Red: Camera starting up.  Slow-flashing Red: Network exception.  Fast-flashing Red: Camera exception (e.g. microSD™ card error).  Solid Blue: Video being viewed in the EZVIZ app.  Slow-flashing Blue: Camera running properly.  Fast-flashing Blue: Camera ready for network connection.
RESET Button	When the camera is working, press and hold the button for 5 seconds to restart and set all parameters to default.
microSD™ Card Slot	<ul style="list-style-type: none"> • Insert a microSD™ card (purchase separately) into the card slot. Initialize the card in the EZVIZ app before using it. • Recommended compatibility: Class 10, maximum space 512GB.



Get the EZVIZ App

- Before downloading the app:
 - If the app is already installed, verify that it is the latest version by checking for updates in your app store.
 - If the app is not installed, follow the steps below to download it.
1. Connect your mobile phone to Wi-Fi (suggested).
 2. Download the EZVIZ app by searching "EZVIZ" in the App Store or Google Play™.
 3. Register an EZVIZ account and log in to the app.

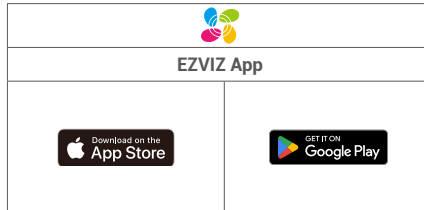

Connect to Power

Connect the power port to a power outlet with the power adapter (included in the package).

- For disconnection from power supply, unplug the power connector from the device.
- When the LED indicator is fast-flashing blue, it indicates that the camera is ready for network configuration.



Connect to Internet

Connect the camera to a wired or Wi-Fi network, then add it to the EZVIZ app.

- Wired connection: connect the camera to a router. Refer to "[Option A: Wired Setup](#)".
- Wi-Fi configuration: configure Wi-Fi settings. Refer to "[Option B: Wi-Fi Setup](#)".

- Network priority: wired network > Wi-Fi.

Option A: Wired Setup

1. Connect the camera to a LAN port of your router using an Ethernet cable (purchase separately).



i When the LED indicator turns slow-flashing blue, it indicates that the camera has been connected to the Internet.

2. Log in to your account in the EZVIZ app.
3. On the Home screen, tap "+" in the upper-right corner to go to the Scan QR Code page.
4. Scan the QR code on the Quick Start Guide cover or on the body of the camera.



i You can also directly enter the device SN for adding.

5. Follow the EZVIZ app wizard to add the camera to your EZVIZ account.

i After a wired connection, if the LED indicator flashes red slowly, the camera has failed to connect to the network. Check if the Ethernet cable is connected properly or loose.

Option B: Wi-Fi Setup

i Please connect your camera to the Wi-Fi to which your mobile phone has been connected.

1. Log in to your account using the EZVIZ app.
2. On the Home screen, tap "+" in the upper-right corner to go to the Scan QR Code page.
3. Scan the QR code on the Quick Start Guide cover or on the body of the camera.



i You can also directly enter the device SN for adding.

4. Follow the EZVIZ app wizard to complete Wi-Fi configuration and add the camera to your EZVIZ account.

Installation

1. Install a microSD™ Card (Optional)

1. Remove the two screws located at the bottom of the device to detach the cover.
2. Insert a microSD™ card (purchase separately) into the card slot.
3. Reattach the cover.



- i** After installing a microSD™ card, please follow the below steps to initialize the card in the EZVIZ app before using it.
1. In the EZVIZ app, tap Record List in the Device Settings page to check the microSD™ card status.
 2. If the microSD™ card status shows as Uninitialized, tap to initialize it. The status will then change to In Use, allowing videos to be stored.

2. Installation Location

- Choose a location with a clear, unblocked field of view.
- Make sure the wall is strong enough to withstand three times the weight of the camera.
- Camera cannot be installed with the lens facing direct sunlight.
- Recommended installation height: 8.2 - 9.8 feet (2.5 - 3 meters) above the ground.

3. Remove Mounting Bracket

Press the locking tabs on both sides of the device body, while gently pulling the mounting bracket outward to release it.

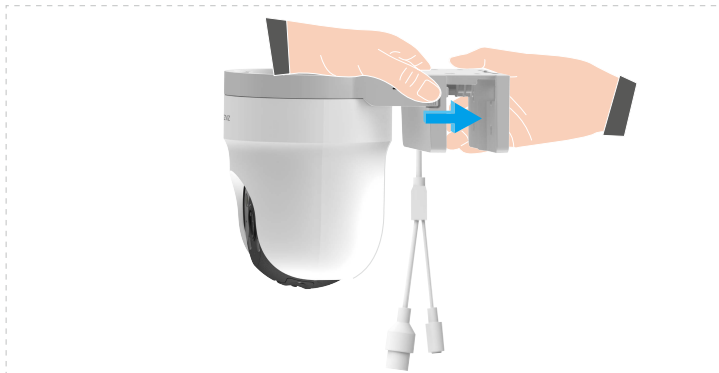

4. Installation Procedure

The camera can be wall mounted, ceiling mounted, and pole mounted.

Ceiling/Wall Mount

1 Before installing the camera onto the mounting bracket, route all cables through the cable channel to prevent interference with subsequent installation steps.

1. Stick the drill template onto a clean and flat surface.
2. (For cement ceiling/wall only) Drill screw holes according to the template, and insert anchors.
3. Use screws (PA4×25) to fix the mounting bracket on the installation surface.
4. Install the camera onto the mounting bracket.

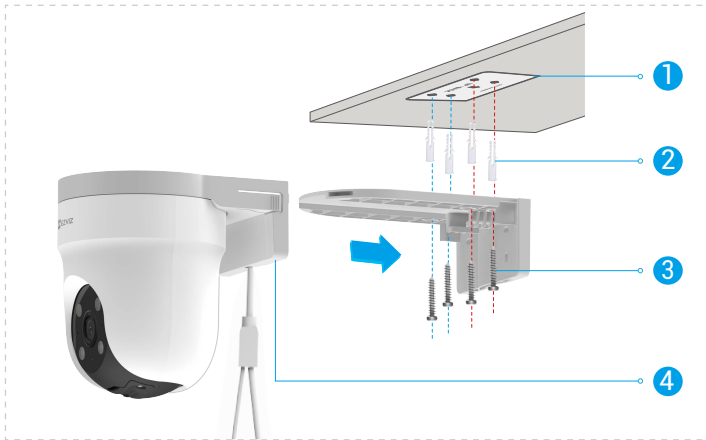

Fig. 1 Ceiling Mount

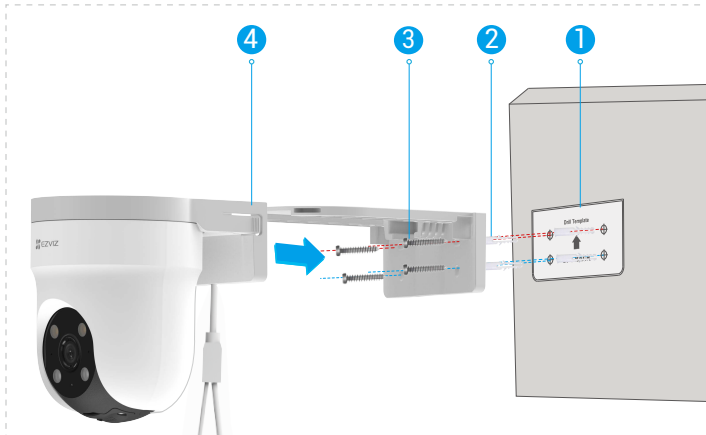
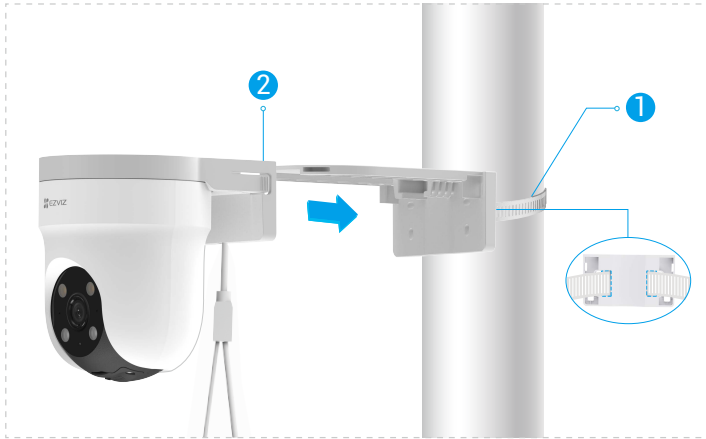

Fig. 2 Wall Mount

Pole Mount

1. Use a hoop (purchase separately) to fix the mounting bracket to a pole.
2. Install the camera onto the mounting bracket.



- 1 After installation, please remove the protective film from the lens.

5. Install the waterproof kit (Optional)

- 1 If the camera is installed outdoors or in humid environments, please use the waterproof kit.

1. Insert the washer into the Ethernet port of the camera.



2. Thread A through the endcap, the gasket and the nut.



3. Thread A into the Ethernet port of the camera.



4. Tighten the nut, the gasket and the endcap.



5. Connect B to a LAN port of the router.

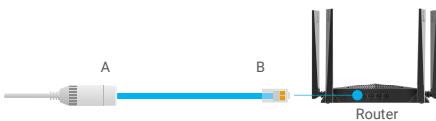

View Your Device

i The app interface may change due to version update.

1. Live View

Launch the EZVIZ app, tap the device card of this peephole to enter the device page. Then tap the Live View button to enter the live view page where you can view and listen to a live feed, take snapshots, record videos, and select a video resolution as needed.

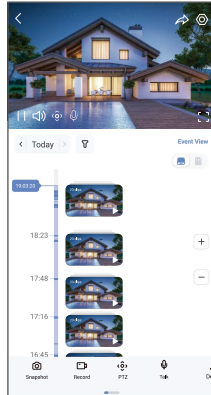

i Swipe left and right across the screen to see more icons.

Icon	Description
	Share. Share your device with anyone you want.
	Settings. View or change the device settings.
	Snapshot. Take a snapshot.
	Record. Manually start/stop recording.
	PTZ. Rotate the camera to get broader field of view.
	Talk. Tap to talk with the people in front of the camera.
	Definition. Tap to select video resolution as you need.
	Sleep. Tap to enable sleep mode, the video will stop displaying and the alarm notification will be turned off.
	Auto Patrol. Tap to enable an automatic patrol and track the target.
	360° Picture. Tap to generate a 360° view picture.
	Alarm. Tap the icon, and the device will make sounds and flash to deter intruders.
	Floodlight. Tap to turn on the floodlight to light up the field of view, and tap it again to turn it off.
	Nearby Device. Tap to select available nearby devices for multi-screen live view.
	PIP. Tap to view the video displayed on top of another app you are using.
	Tip. Tap to see more information about the device.
	Rearrange. Rearrange the sequence of all the functions above.

2. Intelligent Detection

The device supports intelligent detection. Please follow the steps below to configure it.

1. Go to Device Settings > Intelligent Detection.

2. Tap "Apply" to enable the specific AI algorithms for your device.

- 1 After you enable an AI algorithm, tap on it to configure relevant parameters, such as setting detection areas for different lenses and selecting detection sensitivity.



3. After completing the intelligent detection settings, return to the device settings page. Tap "Light Settings" to enable corresponding light notifications, and "Audio Settings" to enable audio settings as needed.

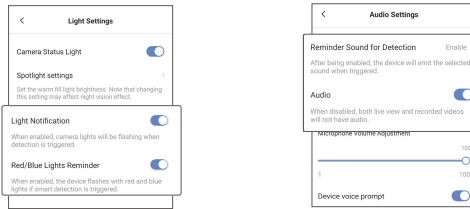

The camera will produce corresponding audible and visual notifications based on the parameters set in the "Light Settings" and "Audio Settings" under the following conditions:

- A human shape is detected in the live view (if "Human Shape Detection" is enabled).
- A vehicle is detected in the live view (if "Vehicle Detection" is enabled).
- A dynamic change is detected in the live view (if "Image Change Detection" is enabled).

EZVIZ Connect

1. Use Amazon Alexa

These instructions will enable you to control your EZVIZ devices with Amazon Alexa. If you run into any difficulties during the process, please refer to Troubleshooting.

Before you start, make sure that:

1. EZVIZ devices are connected to the EZVIZ app.
2. In the EZVIZ app, turn off the "Video Encryption" and turn on the "Audio" in the Device Settings page.
3. You have an Alexa-enabled device (i.e Echo Spot, Echo-Show, All-new Echo-Show, Fire TV (all generations), Fire TV stick (second generation only), or Fire TV Edition smart TVs).
4. The Amazon Alexa app is already installed on your smart device, and you have created an account.

To Control EZVIZ devices with Amazon Alexa:

1. Open the Alexa app and select "Skills and Games" from the menu.
2. On the Skills and Games screen, search for "EZVIZ", and you will find "EZVIZ" skills.
3. Select your EZVIZ device's skill, then tap ENABLE TO USE.
4. Enter your EZVIZ username and password, and tap Sign in.
5. Tap the Authorize button to authorize Alexa to access your EZVIZ account, so that Alexa can control your EZVIZ devices.
6. You will see "EZVIZ has been successfully linked", then tap DISCOVER DEVICES to allow Alexa to discover all your EZVIZ devices.
7. Go back to Alexa app menu and select "Devices", and under devices you will see all your EZVIZ devices.

Voice Command

Discover a new smart device via the "Smart Home" menu in the Alexa app or the Alexa Voice Control function. Once the device is found, you can control it with your voice. Speak simple commands to Alexa.

- ❗ Your device's name for example: "show xxx camera," can be changed in the EZVIZ app. Each time you change the name of the device, you will need to discover the device again to update the name.

Troubleshooting

What should I do if Alexa fails to discover my device?

Check if there are any Internet connecting problems.

Restart the smart device and re-discover on Alexa.

Why the device's status is "Offline" on Alexa?

Your device might have been disconnected from the network. Restart the smart device and re-discover on Alexa.

Check if your router is connected to the Internet and try again.

- ❗ For details about countries where Amazon Alexa is available, see [Amazon Alexa's official website](#).

2. Use Google Assistant

With the Google Assistant, you can activate your EZVIZ device and watch live by speaking Google Assistant voice commands.

The following devices and apps are required:

1. A functional EZVIZ app.
2. In the EZVIZ app, turn off the "Video Encryption" and turn on the "Audio" in the Device Settings page.
3. A TV with functional Chromecast connecting to it.
4. The Google Assistant app on your phone.

To get started, follow the steps below:

1. Set up the EZVIZ device and make sure it works properly on the app.
2. Download the Google Home app from the App Store or Google Play™ and log into your Google account.
3. On the Myhome screen, tap "+" in the upper-left corner, and select "Set up device" from the menu list to go to the Set up interface.
4. Tap Works with Google, and search for "EZVIZ", where you will find "EZVIZ" skills.
5. Enter your EZVIZ username and password, and tap Sign in.
6. Tap the Authorize button to authorize Google to access your EZVIZ account, so that Google can control your EZVIZ devices.
7. Tap Return to app.
8. Follow the above steps to complete the authorization. When synchronization is completed, EZVIZ service will be listed under your list of services. To see a list of compatible devices under your EZVIZ account, tap on the EZVIZ service icon.
9. Now try some commands. Use the name of the camera that you created when you set up the system.

Users can manage devices as a single entity or in a group. Adding devices to a room allows users to control a group of devices at the same time using one command.

See the link for more information:

<https://support.google.com/googlehome/answer/7029485?co=GENIE.Platform%3DAndroid&hl=en>

FAQ

Q: If the camera is offline on the app, will the video recording continue?

A: If the camera is powered on but disconnected to the Internet, then local recording will continue but cloud recording will stop. If the camera is powered off, both video recordings will stop.

Q: Why the alarm is triggered when nobody in the image?

A: Configure a lower value for the detection sensitivity. Please notice that vehicle and animals are also alarm triggering sources.

Q: The mobile phone cannot receive alarm prompts when the camera is online.

A: 1. Make sure that the EZVIZ app is running on your mobile phone and that the relevant detection notification is enabled.

2. For Android system, make sure the app is running in background; and for iOS, enable the message push function in Settings > Notification.

3. If still no alarm prompts, press and hold the RESET button for about 5 seconds restore the camera settings.

Q: Live view or playback failed.

A: Make sure that your network is well connected. Watching live videos needs a good bandwidth. You can refresh the video, or change a network and try again.

 For additional information about the device, please refer to www.ezviz.com/eu.

Initiatives on the Use of Video Products

Dear Valued EZVIZ Users,

Technology affects every aspect of our life. As a forward-looking tech company, we are increasingly aware of the role technology plays in improving efficiency and quality of our life. At the same time, we are also aware of the potential harm of its improper usage. For example, video products can record real, complete and clear images, therefore they hold great values in representing facts. Nevertheless, improper distribution, use and/or processing of video records may infringe on the privacy, legitimate rights and interests of others.

Committed to innovating technology for the good, we at EZVIZ hereby earnestly advocate that every user shall use video products properly and responsibly, thus to collectively create a positive environment where all related practices and usage comply with applicable laws and regulations, respect individuals' interests and rights, and promote social morality.

Here are EZVIZ's initiatives that we'd appreciate your attention:

1. Each individual possesses a reasonable expectation of privacy, and the use of video products should not be in conflict with such reasonable expectation. Therefore, a warning notice which clarifies the monitoring range should be displayed in a reasonable and effective manner, when installing video products in public areas. For non-public areas, the rights and interests of people involved shall be evaluated thoughtfully, including but not limited to, installing video products only after obtaining the consent of the stakeholders, and not installing highly-invisible video products without other's knowledge.
2. Video products objectively records footage of real activities within specific time and space. Users shall reasonably identify the people and rights involved in this scope in advance, to avoid any infringement of portrait, privacy or other legal rights of others while protecting themselves through video products. Notably, if you choose to enable the audio recording function on your camera, it will capture sounds, including conversations, within the monitoring range. We highly recommend a comprehensive assessment on the potential sound sources in the monitoring range, so as to fully understand the necessity and the reasonableness before you turn on the audio recording function.
3. Video products in use will consistently generate audio or visual data from real scenes –possibly including biometric information such as facial images – based on the user's selection of product features. Such data can be used or processed to use. Video products are only technological tools that do not and cannot humanly practice legal and moral standards to guide lawful and proper use of data. It is the methods and purposes of the people who control and use the generated data that make a difference. Therefore, data controllers shall not only strictly abide by applicable laws and regulations, but also fully respect non-obligatory rules including international conventions, moral standards, cultural norms, public order and local customs. Furthermore, we should always prioritize the protection of privacy and portrait rights, and other reasonable interests.
4. The video data continuously generated by video products carries the rights, values and other demands of various stakeholders. Thus, it is extremely crucial to ensure data security and shield the products from malicious intrusions. Every user and data controller shall, undertake all reasonable and necessary measures to maximize product and data security, avoiding data leakage, improper disclosure or misuse, including but not limited to, setting up access control, selecting a suitable network environment where video products are connected, establishing and constantly optimizing network security.
5. Video products have made great contributions to enhance the safety of our society, and we believe that they will continue to play a positive role in various aspects of our daily life. Any attempt to abuse these products to violate human rights or engage in unlawful activities contradicts the very essence of the value in tech innovation and product development. We encourage every user to establish your own methods and rules to evaluate and monitor the use of video products, so as to ensure that these products are always used properly, thoughtfully and with goodwill.

Information For Private Households

1. Separate collection of waste equipment: Electrical and electronic equipment that has become waste is referred to as waste equipment. Owners of waste equipment must dispose of it separately from unsorted municipal waste. In particular, waste equipment does not belong in household waste, but in special collection and return systems.
2. Batteries and rechargeable batteries as well as lamps: Owners of waste equipment shall, as a rule, separate waste batteries and rechargeable batteries that are not enclosed in the waste equipment, which can be removed from the waste equipment without being destroyed, from the waste equipment before handing them in at a collection point. This does not apply if waste equipment is prepared for reuse with the participation of a public waste management authority.
3. Options for returning waste equipment: Owners of waste equipment from private households can return it free of charge to the collection points of the public waste management authorities or to the take-back points set up by manufacturers or distributors within the meaning of the Electrical and Electronics Equipment Law. Stores with a sales area of at least 400 m² for electrical and electronic equipment and those grocery stores with a total sales area of at least 800 m² that offer electrical and electronic equipment several times a year or on a permanent basis and make it available in the market are required to take it back. This also applies in the case of distribution using means of distance communication, if the storage and shipping areas for electrical and electronic equipment are at least 400 m² or the total storage and shipping areas are at least 800 m². Distributors shall, in principle, ensure take-back by providing suitable return facilities at a reasonable distance from the respective end user. The possibility of returning waste equipment free of charge exists for distributors who are obliged to take it back, among other things, if a new similar device that essentially fulfills the same functions is delivered to an end user.
4. Privacy Notice: Waste equipment often contains sensitive personal data. This applies in particular to devices of information and telecommunications technology such as computers and smartphones. In your own interest, please note that each end user is responsible for deleting the data on the waste equipment to be disposed of.
5. Meaning of the symbol "crossed-out wheelee bin": The symbol of a crossed-out wheelee bin regularly depicted on electrical and electronic equipment indicates that the respective device is to be collected separately from unsorted municipal waste at the end of its service life.